

Setup Sheet

Track: Trelleborg EURO 2000

Driver: Hubert Honigl

Indoor
 Outdoor

Smooth
 Rough

Slippery
 High-Bite
 Blue-Groove

Date: July 20, 2000

Tight / Open

FRONT SUSPENSION (Circle or Check the Appropriate Settings)

Toe In 1 °
 Out

of washers under steering / tie-rod ball studs
Spindle ball stud: 1
Bellcrank ball stud: _____

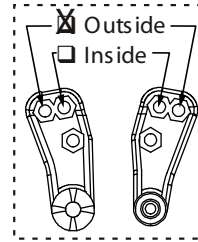

of washers under ball stud
2

Ride Height Arms Level

Camber - 1 °
 +

Caster Stock
 Other _____ °

Sway Bar No
 Yes size _____

Front Shocks
Oil: 25 wt Losi
Piston: 56 Standard / Drilled
Spring: Green
Limiters: Inside- _____ Outside- _____

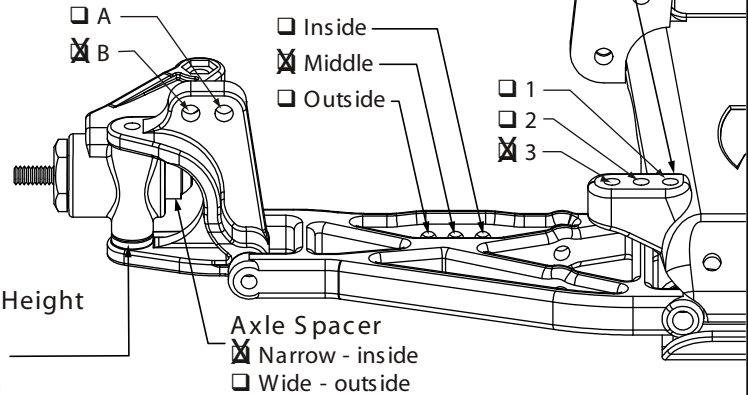

REAR SUSPENSION

Toe-In Inside 3 °
 Outside _____ °

Pivot Support 2 No Shim
 Shim Under Front
 Shim Under Rear } # of shims: 7 °

Ride Height Dogbones level

Camber - 1 °
 +

Drive Shafts Dogbones Aluminum
 CVDs Steel

Rear Hub Spacing Forward
 Center
 Rear

Outdrives Steel
 Plastic

Sway Bar No
 Yes size _____

Rear Shocks
Oil: 27 1/2 wt Losi
Piston: 56 Standard / Drilled
Spring: Red
Limiters: Inside- _____ Outside- _____

Wing Position
 Forward
 Back

Wing Mount
 Top
 Bottom

4
 3
 2
 1

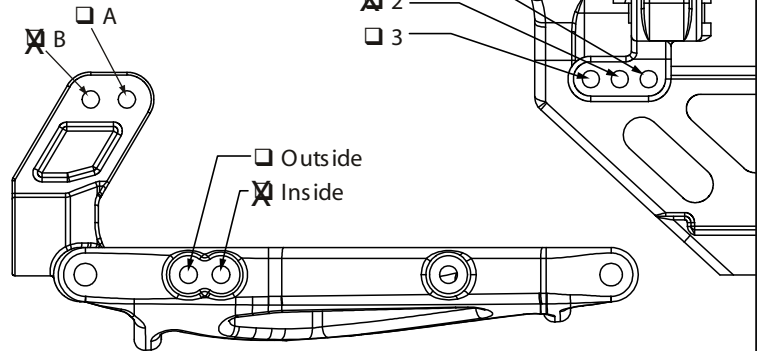

Tires
Front: A-7204 Ex-Wide body Compound Silver Foam Original
Rear: Proline Bow Tie M3 Original

Motor: 11x2 LRP Pinion/Spur: 21/84
Battery Position: Forward

Notes: Front Wing, V-wing, 15g under in front bulkhead