



Setup Sheet

Track: Trelleborg Euro's 2000

Driver: Jukka Steenari

Indoor
 Outdoor

Smooth
 Rough

Slippery
 Medium
 High-Bite

Date: Starting Set-Up

Tight / Open

FRONT SUSPENSION (Circle or Check the Appropriate Settings)

Toe In Out 0 °

Ride Height Arm's Level

Camber - 1/2 °
 +

Caster Stock Other _____ °

Sway Bar No Yes size _____

of washers under steering / tie-rod ball studs
Spindle ball stud: 1 Gold
Bellcrank ball stud: 0

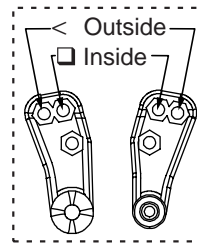

of washers under ball stud: 0

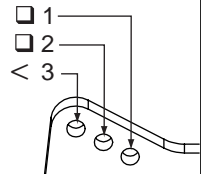

Front Shocks

Oil: 30wt Losi

Piston: 554 q Standard / Drilled

Spring: Green

Limiters: Inside- 0.060" q Outside- _____

Spindle Height

Top
 Middle
 Bottom

Axle Spacer

Narrow - inside
 Wide - outside

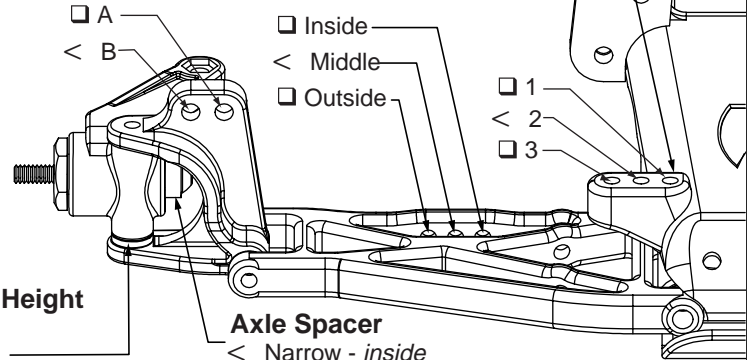

REAR SUSPENSION

Toe-In Inside 3 °
 Outside _____ °

Pivot Support 2deg No Shim
 Shim Under Front
 Shim Under Rear } # of shims: _____

Ride Height Dog Bones Level, Make Chassis Flat

Camber - 1 °
 +

Drive Shafts Dogbones Aluminum
 CVDs Steel

Rear Hub Spacing Forward
 Center
 Rear

Outdrives Steel
 Plastic

Sway Bar No Yes size Usually faster w/0.055" Use when track is smooth

Wing Position

Forward
 Back

Wing Mount

Top
 Bottom

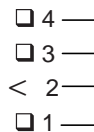

Rear Shocks

Oil: 25wt Losi

Piston: 665 q Standard / Drilled

Spring: Red

Limiters: Inside- 0.060" q Outside- _____

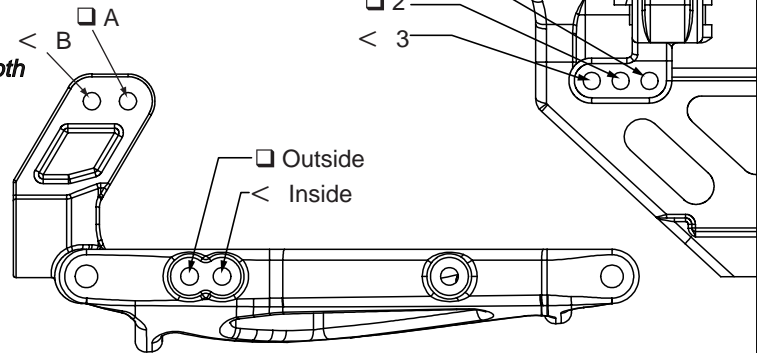

Tires

Front: Wide Body, std. Wheels

Compound

Gold

Foam

Stock

Rear: Big Shot, Wide Wheels

Silver

Losi Firm

Motor: _____ Pinion/Spur: _____ / 78

Battery Position: 10mm Back

Notes: 10g in front Bulkhead, Track has sharp/edgy bumps, good traction w/Loose top surface